



Palazzoli
GROUP



METAL CONSUMER UNITS

NEW & IMPROVED
RANGE

EXTRA
HEIGHT

IDEAL FOR RCBO INSTALLATION

Fully compliant with the new 18th Edition of the IET Wiring Regulations BS7671:2018

18TH EDITION AT A GLANCE



Lewden is committed to the safety of electrical installers and end users by being at the forefront of ensuring compliance with the new 18th edition of the IET wiring regulations BS7671:2018 that came into full effect from 1st January 2019, bringing about new guidelines and recommendations for all the professionals involved in design and maintenance of electrical installations.

A bite sized look at some of the regulation changes that relate specifically to the installation of consumer units.

536.4.203 USE OF APPROVED PARTS

In low voltage assemblies to the BS EN61439 series, e.g. consumer units & distribution boards, incorporated devices and components shall only be those declared suitable according to the assembly manufacturer's instructions or literature. Use only manufacturer approved parts, or if in doubt consult the consumer unit manufacturer to confirm compatibility. If an assembly deviates from its original manufacturer's instructions, or includes components not included in the original verification, the person introducing the deviation becomes the original manufacturer with the corresponding obligations.

522.8.5 STRAIN RELIEF OF METER TAILS

Every cable or conductor shall be supported in such a way that it is not exposed to undue mechanical strain and so that there is no appreciable mechanical strain on the terminations of the conductors. Consumer unit meter tails are included in the requirements of this regulation.

Within consumer units, utilising the Lewden meter tails clamp accessory (MTC) satisfies this requirement.

411.3.4 ADDITIONAL RCD PROTECTION FOR LIGHTING CIRCUITS

Within domestic premises, additional protection by an RCD with a rated residual current not exceeding 30mA shall be provided for AC final circuits supplying luminaires.

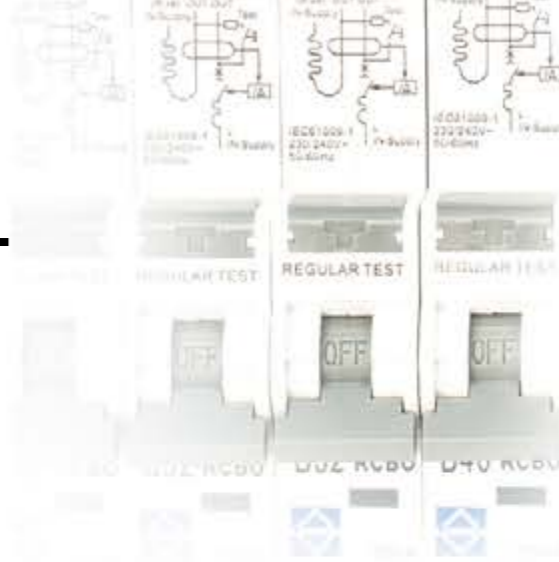

Class AC : For general purpose use on pure AC 50/60 Hz



Class A : For use on pure AC & Pulsating DC up to 6mA

531.3.2 CONSIDERATIONS FOR UNWANTED TRIPPING OF RCDS

New considerations shall be given to the selection of residual current devices so as to limit the risk of unwanted tripping during normal (non-fault) operation. The following shall be considered;

1. Sub division of circuits using individual RCDs/RCBOs. Devices shall be selected and circuits sub divided in such a way that any earth leakage current likely to occur during normal operation of connected load devices will not cause unwanted tripping of the device.
2. In order to avoid unwanted tripping by PE currents and/or earth leakage currents during normal (non-fault) operating conditions, the accumulation of such currents downstream of the RCD shall be not more than 30% of the rated residual operating current. Designers must take account of PE currents when sub-dividing the installation into the appropriate number of circuits.

531.3.3 TYPES OF RCD

RCCBs & RCBOs are available in various types, which are categorised depending on their behaviour in the presence of DC components or different frequencies.

The designer of an installation must select the appropriate device type for the specific application.

RCD Class	Classification	Symbol	Type of load suited to	Examples
AC	General purpose use on pure AC 50/60Hz only. Not suitable where pulsating DC exists		Resistive, Capacitive, and inductive loads that do not feature any electronic components	<ul style="list-style-type: none"> • Immersion heater • Oven or hob with resistive elements • Electric shower • Tungsten & halogen lighting (no LED)
A	Suitable for use on pure AC and where pulsating DC exists up to 6mA		Equipment that features electronic components Type A devices are also suitable for AC applications	<ul style="list-style-type: none"> • Inverters • Class 1 IT and multimedia equipment • Power supplies for class 2 equipment • Washing machines that are not frequency controlled • Lighting controls such as electronic dimmer switches, and building electronic systems. • LED drivers • Induction hobs • Electric vehicle charging where any smooth DC fault current is <6mA
F	AC + A + high frequency 10Hz < 1KHz		Equipment with frequency controlled speed drives Type F devices are also suitable for type AC and A applications	<ul style="list-style-type: none"> • Some washing machines, dishwashers and tumble dryers e.g. containing synchronous motors • Some class 1 power tools • Some air conditioning controllers using variable speed frequency drives
B	AC + A + smooth DC + high frequency 10Hz < 1KHz		Photo voltaic supplies & electric vehicle charging equipment Type B devices are also suitable for type AC, A, and F applications	<ul style="list-style-type: none"> • Inverters for speed control • UPS, Computer data centres • Electric vehicle charging stations where any smooth DC fault current is >6mA • Photo voltaic (solar) systems (AC side) • Power electronic converter systems (PECS), typically industrial machines, cranes, elevators

SURGE PROTECTION DEVICES

BS7671: 2018 REGULATION CHAPTERS 443 AND 534

Following the implementation of the 18th edition, the use of surge protection devices looks set to become more widespread within distribution boards, for both single and three phase applications.

Electrical surges can originate from two different sources;

1. Atmospheric, in the form of direct or indirect lightning strikes.
2. Transient voltage surges can be created by the switching of electrical equipment such as LED lighting / drive motors / lifts / refrigeration equipment / welding equipment etc, or when power is switched or re-established by the utility company following a substation outage or distribution network fault.

Whilst lightning strikes are significantly more powerful than transient voltage surges, the latter occurs far more frequently.

The greater the amplitude of the surge, the higher the risk of disruption, degradation, damage, or destruction to the electrical equipment and wiring that is connected to the supply. The effects of a lightning strike can cause irreparable damage to electrical equipment located up to 2km away.

THE 18TH EDITION REGULATIONS REGARDING PROVISION OF SURGE PROTECTION:

The 18th edition wiring regulations (BS7671:2018) 443.4 requires that all new installations, and additions/alterations to existing installations are assessed against the risks of transient over voltage.

Protection against surge shall be provided where the consequence caused could;

1. Result in serious injury to or loss of human life (Examples are areas containing medical equipment, emergency lighting, fire alarm panels etc).
2. Result in interruption of public services, and/or damage to cultural heritage (Examples include data centres, power stations, museums, libraries, art galleries etc).
3. Result in interruption of commercial or industrial activity (Examples include manufacturing and industrial locations, retail outlets, hotels, banks, offices etc)
4. Affect a large number of co-located individuals (Examples include education centres, residential apartment blocks etc)

For all other cases not listed above, a risk assessment shall be carried out using the method outlined in regulation 443.5, to determine whether protection against transient over voltage of atmospheric origin is required. If no transient overvoltage



Type 2 Retrofit Surge Protection Unit

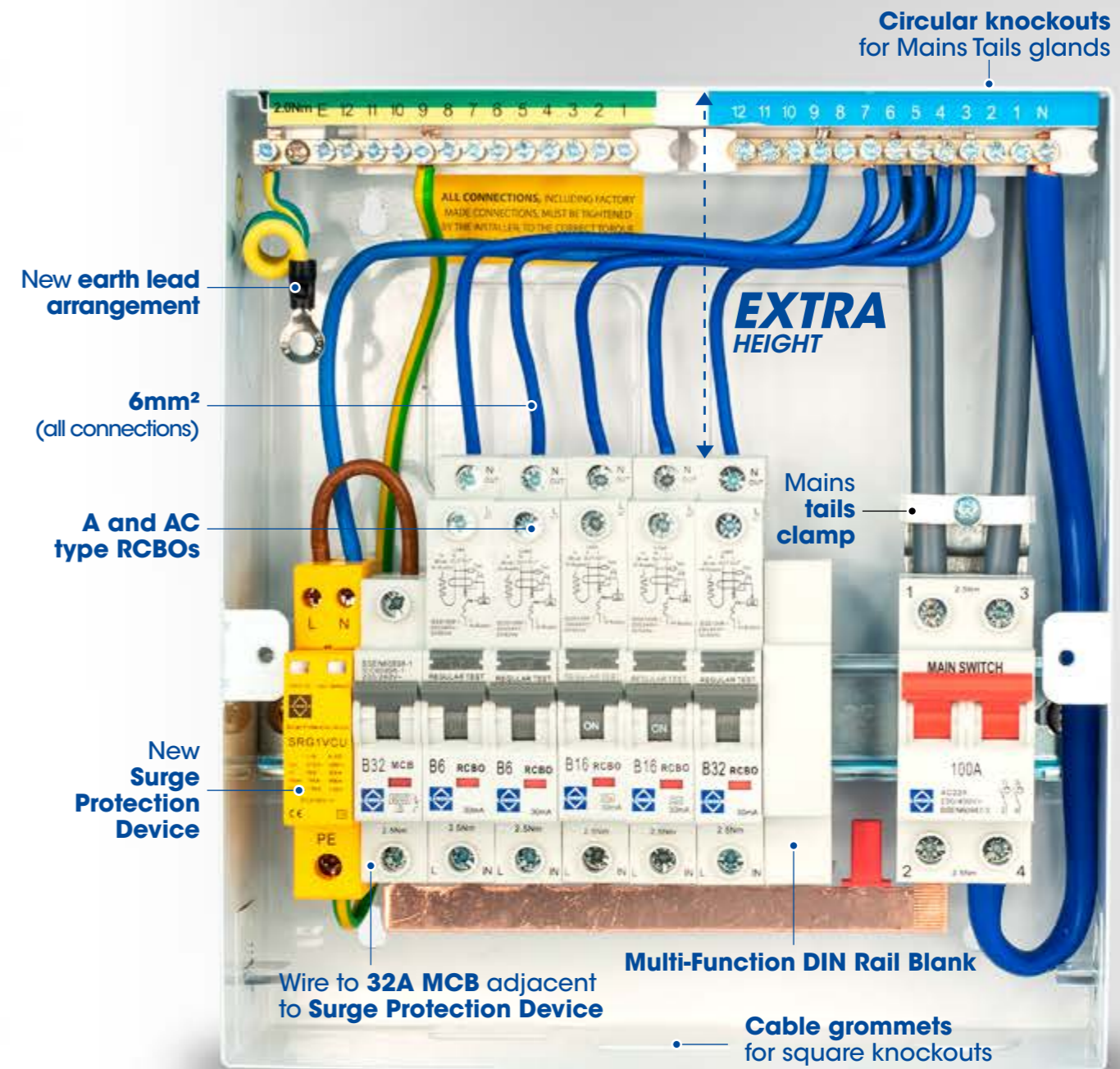

protection against disturbances of atmospheric origin is installed, protection against switching over voltages may still need to be provided. If a risk assessment is not performed, the installation shall be provided with protection against transient over voltages.

An exception is permitted for single dwelling units if the total value of the wiring installation and equipment connected to it does not justify the cost of incorporating such protection. In practice however, it is considered unlikely that the value of the installation and load equipment will not justify the cost of incorporating surge protection.

Surge protection devices are sacrificial items designed to absorb and discharge any surges that may occur on the electrical system. They are connected in parallel to the outgoing circuits on the consumer unit or distribution board, hence one device will provide protection for all outgoing circuits on that distribution board. It is important to note that the load current of distribution circuits does not pass through the device. Where an installation contains more than one distribution board, and the boards are located at cable distances >10m apart, surge protection will be required at each distribution board, and co-ordinated with one another.

SURGE PROTECTION DEVICES

TYPES OF SURGE PROTECTION DEVICES:

Surge devices are categorised into three types, according to their strength;

Type 1: These devices offer protection against the effects of a lightning surge. The devices must be installed at the origin of the electrical installation, where they guard against direct lightning currents entering the system from outside the premises. They must be able to withstand large amounts of charge and energy. Type 1 devices must be installed where buildings include a lightning protection system, or the building is fed from overhead power lines (which themselves are at direct risk of lightning strike).

Type 2: These devices are designed for use within sub-distribution boards located downstream of a type 1 device, OR at the origin of an installation only where there is little or no risk from direct lightning strike (as determined by the risk assessment calculation). Type 2 devices cannot offer protection against the effects of a direct lightning surge. They are primarily suitable for buildings located in an urban area, without an external lightning protection system, and fed from an underground power source.

Type 3: These devices are the smallest of the 3 types, and are designed to be installed downstream of type 1 or 2 devices where they afford protection to individual pieces of sensitive or valuable electrical/electronic equipment. Type 3 SPDs cannot be installed at the origin of an installation.

DOES ONE PRODUCT FIT ALL APPLICATIONS ?

Most devices available within the market for the protection of AC power circuits comprise a metal oxide varistor (MOV), which is the technology most commonly used. The surge current rating of an MOV is related to its cross sectional area and its material composition. Generally, the larger the cross sectional area of the MOV, the higher the kA rating of the device. Devices that comprise of a single MOV are only suitable for power distribution systems with a TN-C-S earth arrangement, however it does not offer protection on the neutral wire – hence you really need two of them. Devices that are suitable for TN-S earth systems feature 2x MOV. These can also be used on TN-C-S systems.

Surge protectors that can be installed on both TN (TN-S & TN-C-S) and also TT earth arrangements feature an additional element; a gas discharge tube (GDT), connected internally between the neutral and earth conductors. The combined TN/TT device is considerably more flexible in its design, as this device can be deployed into any system no matter which earthing arrangement is utilised. All Lewden surge protection devices are combined TN/TT devices.

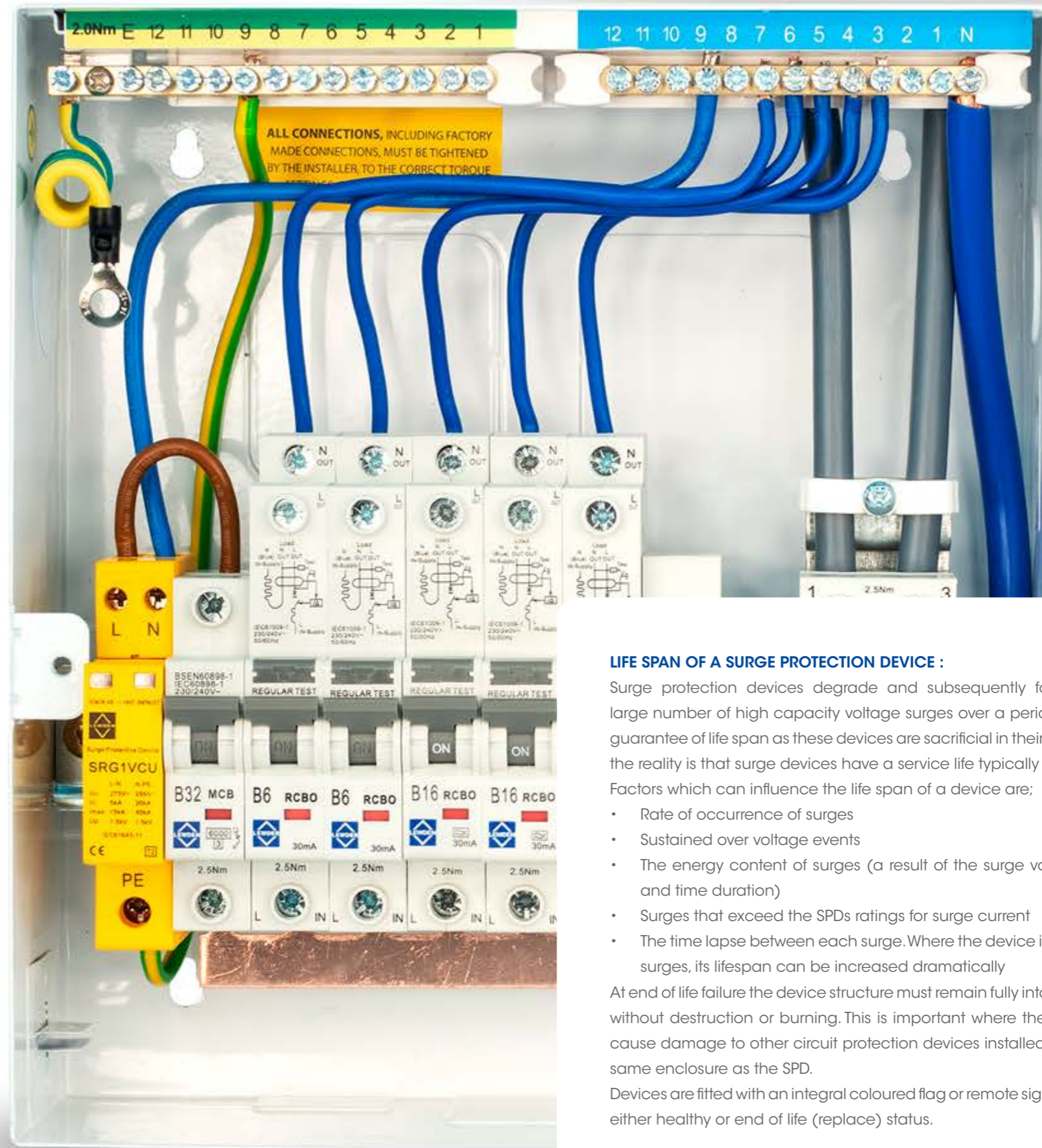

LIFE SPAN OF A SURGE PROTECTION DEVICE :

Surge protection devices degrade and subsequently fail when subjected to a large number of high capacity voltage surges over a period of time. There is no real guarantee of life span as these devices are sacrificial in their duty, although in practice the reality is that surge devices have a service life typically between 5-10 years.

Factors which can influence the life span of a device are;

- Rate of occurrence of surges
- Sustained over voltage events
- The energy content of surges (a result of the surge voltage and current values and time duration)
- Surges that exceed the SPDs ratings for surge current
- The time lapse between each surge. Where the device is allowed to cool between surges, its lifespan can be increased dramatically

At end of life failure the device structure must remain fully intact (i.e. IP20 classification), without destruction or burning. This is important where the device could potentially cause damage to other circuit protection devices installed adjacent to or within the same enclosure as the SPD.

Devices are fitted with an integral coloured flag or remote signalling contact, indicating either healthy or end of life (replace) status.

WARRANTY PERIOD

Lewden surge protection devices come with a 5 year warranty period as standard.

OVERLOAD PROTECTION OF AN RCCB OR SWITCH

BS7671:2018 REGULATION CLAUSES

536.4.3.2, 536.4.5 AND 536.4.202

Residual current circuit breakers (complying with EN61008-1) are intended to protect persons against electric shock, whilst switches (complying with EN60947-3) are used to isolate circuits or switch loads.

As neither of these devices provide protection against overload or short circuit, they therefore need to be protected by a suitably rated overcurrent protective device (OCPD).

To achieve overload protection of RCCBs or switches, the rated current of the OCPD shall be co-ordinated according to the manufacturer's instructions;

Consumer Unit Type	Minimized inconvenience	Testing & Maintenance	Diversity Factor Free	Upstream Cut out Fuse		
				63A	80A	100A
RCBO Board	✓	✓	✓	✓	✓	✓
63A Incomer RCCB Board	✗	✗	✗	✓	✗	✗
80A Incomer RCCB Board	✗	✗	✗	✓	✓	✗
100A Incomer RCCB Board	✗	✗	✗	✓	✓	✓

APPROACH 1 - An RCBO consumer unit, with overload protection provided by each RCBO

Utilising a consumer unit comprising a 100A rated main switch, and individual RCBOs on the outgoing circuits is considered the best approach. Overload protection to each outgoing circuit is provided by the corresponding RCBO, and consideration to spare ways and future additions is therefore automatically compensated for.

This method also allows a better selection of the type of RCBO required according to the nature of the load circuit (with type AC or A options available in the Lewden range).

Furthermore, by distributing load equipment across a greater number of individual RCBO circuits, this greatly assists in reducing the possibility of nuisance tripping, or inconvenience caused by loss of supply to multiple circuits in the event of a residual current fault. With this method, the main switch and distribution bus bar are each rated to 100A, this being the maximum permissible cut out fuse rating installed by the supply authority to domestic properties.

BEST APPROACH

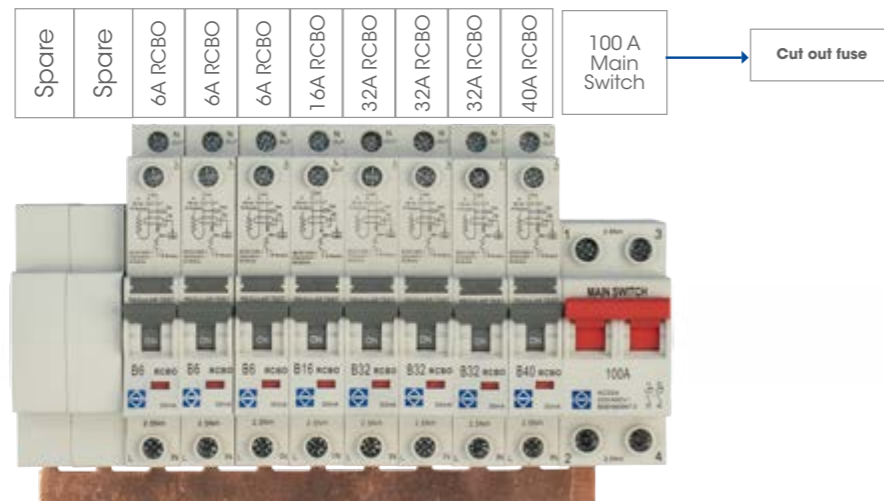

APPROACH 2a - A dual RCCB consumer unit, with overload protection provided by the upstream supply authority cut out fuse.

When installing a dual RCCB consumer unit, the main switch, the RCCBs and the interconnecting wiring are all protected against overload by the supply authority cut-out fuse. Ensure that the individual rated current of each of the RCCBs and the main switch is not less than the rating of the cut out fuse.

For a domestic installation, the cut out fuse may have a 63A, 80A, or 100A rating, depending on factors such as the age & size of the property, and also the relevant supply authority's standard installation procedure.

As with approach 1, this method automatically caters future use of spare ways. Lewden RCCBs are available in 63A (type AC or A), 80A (type AC or A), and 100A (type A) versions to cater for all eventualities.

APPROACH 2b - A dual RCCB consumer unit, with overload protection provided by sum of the rated current of the downstream distribution MCBs.

If using this method, ensure that the total sum of the rated current of all outgoing MCBs connected to the load side of an RCCB or switch does not exceed the rated current of that RCCB or switch.

Using this method means that consideration must be given to the consequences of any future use of spare ways.

Overload Protection of RCCB by Sum of Rated Current of Downstream Devices Examples:

Example	RCCB Rating	Sum of Rated Current	RCCB Rating	Status
Example 1 80A RCCBs	80A RCCB1	76A	< 80A	✓
	80A RCCB2	54A	< 80A	✓
Example 2 63A RCCBs	63A RCCB1	76A	> 63A	✗
	63A RCCB2	54A	< 63A	✓

Maximum Demand of the installation can be calculated based on the application of Diversity Factors

$$\begin{aligned}
 100\% \text{ of Largest Load} &= 32A \\
 +40\% \text{ of All other loads} &= 39.2A = (6A+16A+32A+6A+6A+32A) \times 0.4 \\
 \hline
 &= 71.2A = \text{Rated Current of Consumer Unit Assembly (InA)}
 \end{aligned}$$

Note: Due consideration must be given to future load circuits fitted to spare ways.

NEW AND IMPROVED 18th EDITION COMPLIANT CONSUMER UNITS



An attractively designed range including populated as well as unpopulated enclosures for housing modular components and to allow on-site design flexibility.

- Six modular enclosure sizes including 4,8,10,12,16 and 21
- Extra wiring space designed for the installation of single module RCBOs
- Earth and neutral terminals clearly labelled and positioned at the top
- Selection of knockouts for mini trunking and conduits to ensure quick and neat installation
- 32 maximum usable ways
- Shroud for the protection of live bus bars.

In order to make it feasible for installers to meet with the new criteria of the 18th edition wiring regulations, Lewden consumer units now incorporate a number of new design features:



RCCB / RCBO OPTIONS

Lewden RCCBs and RCBOs are available in both type AC and type A versions, offering the installer the option to choose the correct protection device for the load application. The range also includes 100A rated RCCBs in type A, in 30mA and 100mA time delayed versions.



ONE EXTRA MODULE FOR THE INSTALLATION OF SPD

Each consumer unit enclosure in the range now includes one additional modular way, specifically to allow for the installation of a surge protection device, whilst maintaining the original overall dimensions of the enclosure.

Note: Surge protection devices are connected via cables, and not directly to the comb bus bar. Hence the additional way is not present on the comb bus bar. The consumer units are therefore designated as xx ways +1.



SELECTION OF ROUND AND RECTANGULAR KNOCKOUTS

32mm round knockouts are provided (on both the top and bottom faces of the enclosure) positioned perpendicular to the main switch. There are also two side face knockouts, one 32 and one 40mm diameter to accept circular mains tail cable glands. Rectangular knockouts are maintained for all outgoing ways, with dimensions corresponding to standard PVC mini trunking.



LID EARTH CONNECTION FOR EASE OF INSTALLATION

The introduction of an additional way on the main earth bar ensures faster and easier connection of the equipotential bond to the enclosure lid.



MAINS TAILS CLAMP FOR STRAIN RELIEF OF MAINS TAILS

Pre-drilled fixing holes are provided for easy installation of the mains tails clamp (MTC). The clamp provides additional support and mechanical strain relief for incoming tails as required by 18th edition regulation 522.8.5

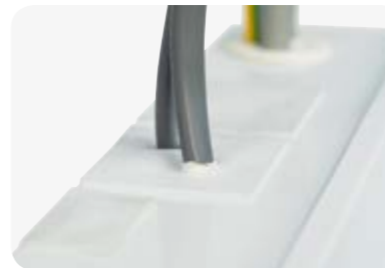

CABLE GROMMETS TO MAINTAIN INGRESS PROTECTION AND PROTECT CABLE INSULATION

The range offer includes two sizes of blind grommet, designed for use in the rectangular knockouts of Consumer Unit enclosures.

The grommets ensure that the enclosure ingress protection rating (IP4X along the top face and IP2XC along the side and bottom faces) can be maintained following the opening of cable entry holes. One sample grommet of each size (CUGR-4025 & CUGR-5050) is provided within the consumer unit accessories pack.



BLANKING OF SPARE WAYS

Two methods are offered for the blanking of consumer unit spare ways:

MFDRB - Multi-Function DIN Rail Blank:

This single module blank attaches to the DIN rail and cannot be removed whilst the front cover is fitted, offering a high level of protection against access to live components.

CU-BL Blanking Strip:

Press-in blanks installed in front cover aperture. These finger-proof covers can be removed with an appropriate tool.



METAL CONSUMER UNITS



I RCBO BASED SOLUTION FOR OVERLOAD PROTECTION

II DUAL RCD BASED SOLUTION FOR OVERLOAD PROTECTION



UNPOPULATED BOARDS

- Supplied complete with Main Switch
*One extra module for the installation of SPD

Part Number	Main Switch Rating	*Total Ways	Drawing Reference
QFS-MX04M	100A	2+1	Module 04
QFS-MX08M	100A	6+1	Module 08
QFS-MX10M	100A	8+1	Module 10
QFS-MX12M	100A	10+1	Module 12
QFS-MX16M	100A	14+1	Module 16
QFS-MX20M	100A	19+1	Module 21
QFS-MX22MG	100A	22	Module 22



POPULATED DUAL RCCB BOARDS Class AC

* One extra module for the installation of SPD

Part Number	Main Switch Rating	*Total Ways	Main Switch	RCCB 63A 30mA Class AC	MCBs (B Type)		Drawing Reference
					6A	16A	
QFS-PM10	100A	10+1	1	2	2	1	Module 10



SEMI-POPULATED DUAL RCCB BOARDS Class A

- Supplied complete with Main Switch and Two RCCBs
*One extra module for the installation of SPD

Part Number	Main Switch Rating	*Total Ways	Main Switch	RCCB 80A 30mA Class A	Drawing Reference
QFS-MX12RRMFLEXIA	100A	6+1	1	2	Module 12
QFS-MX16RRMFLEXIA	100A	10+1	1	2	Module 16
QFS-MX20RRMFLEXIA	100A	15+1	1	2	Module 21



RCBOs - 1 POLE + UNSWITCHED NEUTRAL Class AC / Class A

Rated Current	Class AC		Class A	
	6kA - B Type 30mA	6kA - C Type 30mA	6kA - B Type 30mA	6kA - C Type 30mA
6	RCBO-06/30/SP	RCBO-06/30/1M/C	RCBO-06/30/SPA	RCBO-06/30/1M/CA
10	RCBO-10/30/SP	RCBO-10/30/1M/C	RCBO-10/30/SPA	RCBO-10/30/1M/CA
16	RCBO-16/30/SP	RCBO-16/30/1M/C	RCBO-16/30/SPA	RCBO-16/30/1M/CA
20	RCBO-20/30/SP	RCBO-20/30/1M/C	RCBO-20/30/SPA	RCBO-20/30/1M/CA
32	RCBO-32/30/SP	RCBO-32/30/1M/C	RCBO-32/30/SPA	RCBO-32/30/1M/CA
40	RCBO-40/30/SP	RCBO-40/30/1M/C	RCBO-40/30/SPA	RCBO-40/30/1M/CA
50	RCBO-50/30/SP	RCBO-50/30/1M/C	RCBO-50/30/SPA	RCBO-50/30/1M/CA



UNPOPULATED DUAL RCCB BOARDS

- Complete with Main Switch
- Supplied with all internal connections allowing the user to select the desired RCCB rating and type.
- RCCBs not included.
* One extra module for the installation of SPD

Part Number	MS Rating	*Total Ways	Drawing Reference
QFS-MX12XXM	100A	10+1	Module 12
QFS-MX16XXM	100A	14+1	Module 16
QFS-MX20XXM	100A	19+1	Module 21



SURGE PROTECTION DEVICES

Refer to section IV on page 16

METAL CONSUMER UNITS

II

DUAL RCD BASED SOLUTION FOR OVERLOAD PROTECTION



RCCB – 2 POLE Class AC / Class A

*subject to availability

Rated Current	Tripping Threshold	Part Numbers	
		Class AC	Class A
63A	30mA	*63/30/2	63/30/2A
80A		*80/30/2	80/30/2A
100A	100mA	-	100/30/2A
		-	100/100/2A



MCBS – 1 POLE

Rated Current	6kA - B Type	6kA - C Type
6A	G06-1B06	G06-1C06
10A	G06-1B10	G06-1C10
16A	G06-1B16	G06-1C16
20A	G06-1B20	G06-1C20
32A	G06-1B32	G06-1C32
40A	G06-1B40	G06-1C40
50A	G06-1B50	G06-1C50



SURGE PROTECTION DEVICES

Refer to section IV on page 16

III

RCD INCOMER BASED SOLUTION FOR OVERLOAD PROTECTION



RCCB Incomer Class AC

- Supplied complete with One RCCB
* One extra module for the installation of SPD

Part Number	RCCB 63A 30mA Class AC	RCCB 80A 30mA Class AC	*Total Ways	Drawing Reference
QFS-MX04R	1	-	2+1	Module 04
QFS-MX08R	1	-	6+1	Module 08
QFS-MX10R	-	1	8+1	Module 10
QFS-MX12R	-	1	10+1	Module 12



MCBS – 1 POLE

Rated Current	6kA - B Type	6kA - C Type
6A	G06-1B06	G06-1C06
10A	G06-1B10	G06-1C10
16A	G06-1B16	G06-1C16
20A	G06-1B20	G06-1C20
32A	G06-1B32	G06-1C32
40A	G06-1B40	G06-1C40
50A	G06-1B50	G06-1C50



SURGE PROTECTION DEVICES

Refer to section IV on page 16

METAL CONSUMER UNITS



IV SURGE PROTECTION DEVICES

V SUB - DISTRIBUTION



SINGLE AND THREE PHASE SPDs

- SRG1VCU requires 32A MCB which utilizes one of the consumer unit outgoing ways.

Part Number	Description
SRG1VCU	Type 2, Single Phase , TT/TN-S, 1 Module
SRG1V1G	Type 2, Single Phase , TT/TN-S, 2 Module
SRG3V1G	Type 2, Three Phase , TT/TN-S, 4 Module
SRG1123	Type 1,2 & 3 Combined , Single Phase, TT-TN-S, 2 Module
SRG3123	Type 1,2 & 3 Combined , Single Phase, TT-TN-S, 4 Module



RETROFIT SURGE PROTECTION

Part Number	Description
SRG1VCU-RM	IP20, Steel enclosure c/w Main Switch, MCB and SRG1VCU
SRG1VCU-RP	IP55, Plastic Enclosure c/w Main Switch, MCB and SRG1VCU

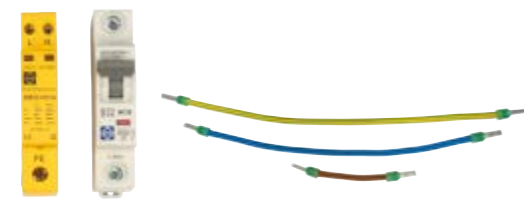

SURGE PROTECTION KIT

For integrated installation within Lewden Consumer Units

Part Number	Description
SRG1VCU-KIT	SRG1VCU + MCB + Cable set for Lewden Consumer Units



GARAGE UNITS

* One extra module for the installation of SPD

Part Number	MS Rating	*Total Ways	Main Switch	RCCB 63A 30mA Class AC	MCBs (B Type)		Drawing Reference
					6A	16A	
QFS-MCGARAGE-63	-	2+1	-	1	1	1	Module 04
QFS-MCGARAGE-MS	100A	2+1	1	-	1	1	Module 04



100A DP FUSED SWITCH

Part Number	Description	Dimensions (mm)		
		H	W	D
FS6380100	100A Fused Switch (Metal / AC21) including 63A, 80A & 100A fuses (22 x 58 IEC 60269-2) gG	250	135	87



MAIN SWITCH FUSE

Part Number	Description	Dimensions (mm)		
		H	W	D
MSF	Main Switch Fuse including 80A Fuse	80	127	54
MSF-CD	MSF(CD) Cable duct for Main Switch Fuse	-	-	-

METAL CONSUMER UNITS



V SUB - DISTRIBUTION



EMPTY UNPOPULATED MODULAR ENCLOSURES

Part Number	Module
QFS-MC04ENC	4 Module
QFS-MC08ENC	8 Module
QFS-MC10ENC	10 Module
QFS-MC12ENC	12 Module
QFS-MC16ENC	16 Module
QFS-MC20ENC	21 Module
QFS-MC32ENC	32 Module

ACCESSORIES

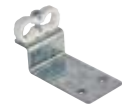

Mains Tail Clamp

Part Number

MTC

1 in each pack



Small Cable Grommets

Part Number

CUGR-4025

40mm x 25mm (Pack of 10)



Large Cable Grommets

Part Number

CUGR-5050

50mm x 50mm (Pack of 10)



Multi-Function DIN rail blank

Part Number

MFDRB

1 in each pack



Blanking strip

Part Number

CU-BL

2 Blanking strips of 6 ways in each pack



Padlock for MCBs, RCCBs and RCBOs

Part Number

MCBLOCK

3 keys, Yellow Hazard Indicator

ACCESSORIES

CABLE GROMMETS

Creates a seal around the cable to maintain IP4X ingress protection and helps to protect cable insulation.

MAINS TAILS CLAMP

Provides appropriate support and strain relief for the meter tails and ensures cable alignment with the main switch, preventing movement of the conductors.



MULTI - FUNCTION DIN RAIL BLANK & BLANKING STRIP

Ensure a higher degree of security for the electrical installers and end users by covering unused ways and avoiding access to the live components through a single module blank designed for installation directly onto the DIN rail or a blanking strip comprising of press-in covers for spare ways in front cover aperture.

DIMENSIONAL DRAWINGS

MODULE 04

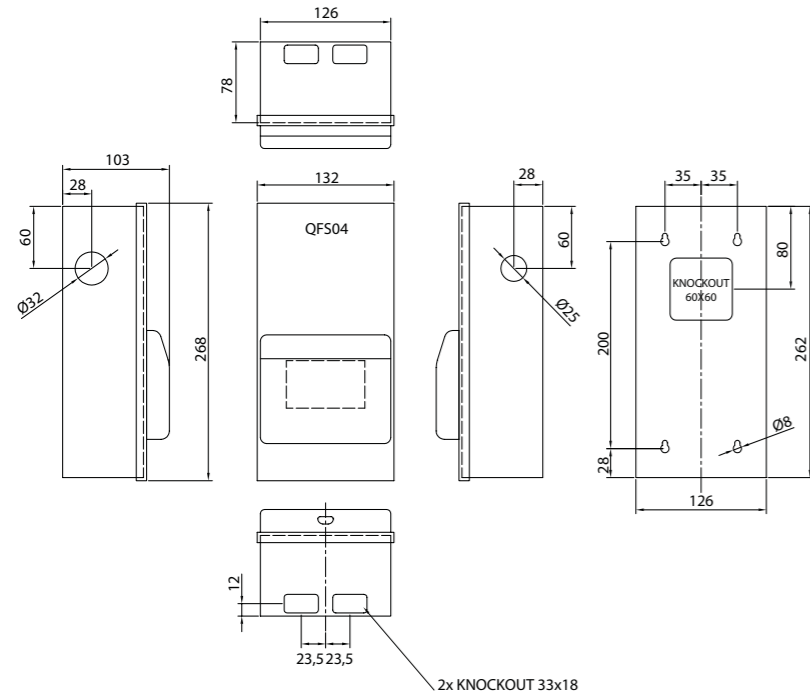

Cable Grommets	
CUGR-4025	4
CUGR-5050	0

MODULE 08

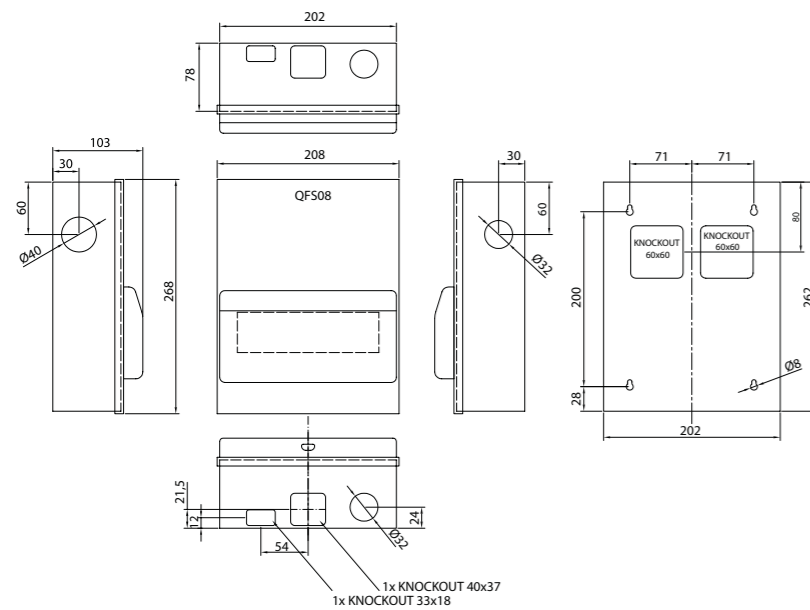

Cable Grommets	
CUGR-4025	2
CUGR-5050	2

DIMENSIONAL DRAWINGS

MODULE 10

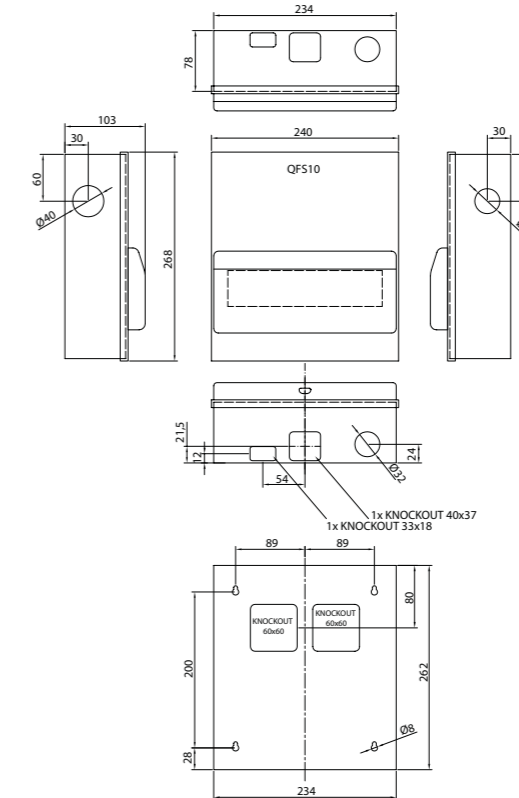

Cable Grommets	
CUGR-4025	2
CUGR-5050	2

MODULE 12

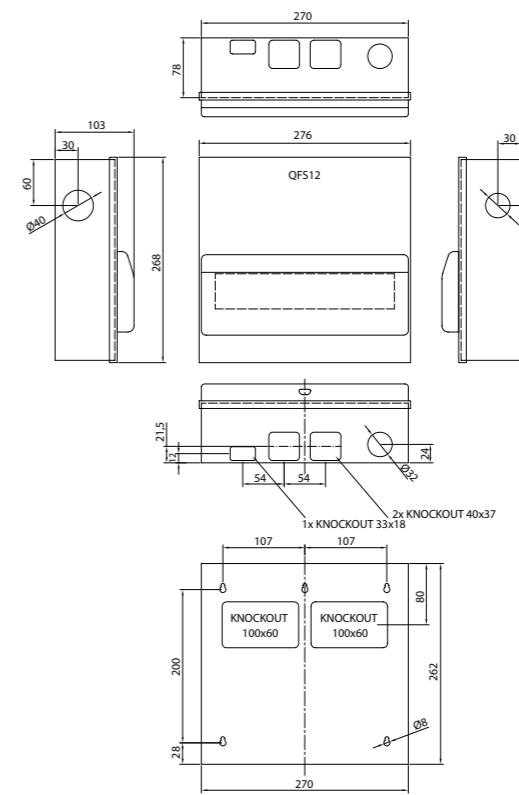

Cable Grommets	
CUGR-4025	2
CUGR-5050	4

DIMENSIONAL DRAWINGS

MODULE 16

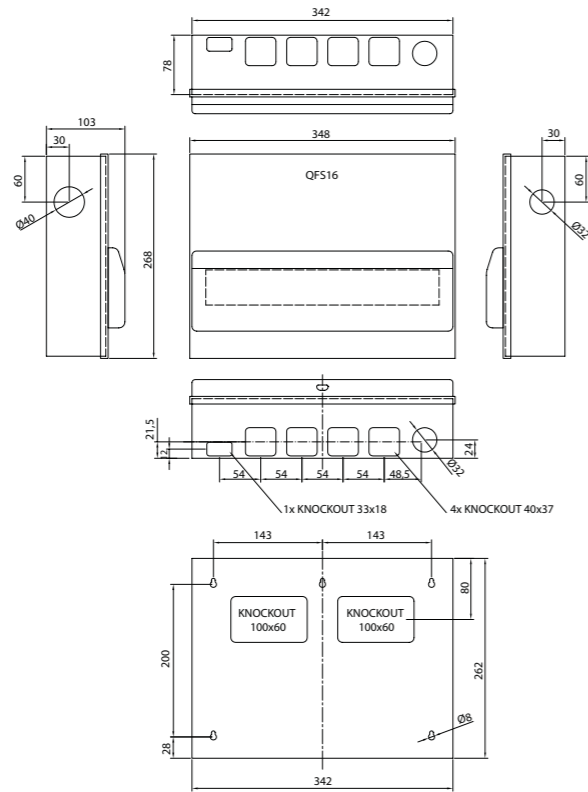

Cable Grommets	
CUGR-4025	2
CUGR-5050	8

DIMENSIONAL DRAWINGS

MODULE 22

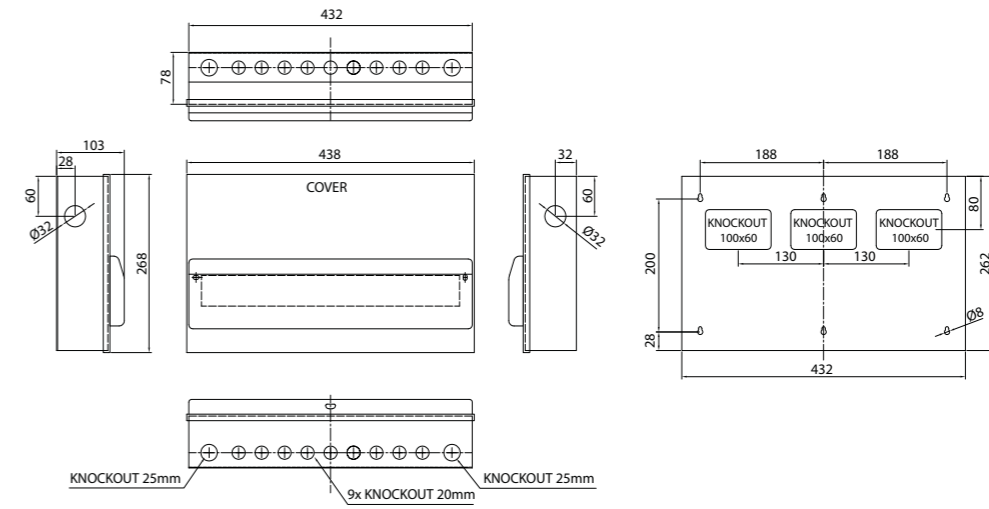

MODULE 21

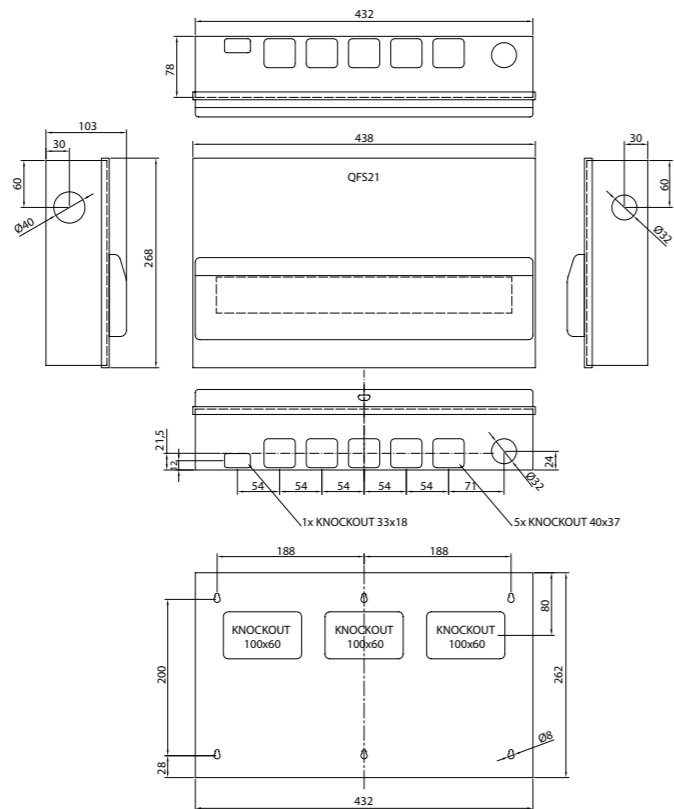

Cable Grommets	
CUGR-4025	2
CUGR-5050	10

MODULE 32

